

Ultrasonic proximity sensors UPX Series

- Detection range up to 500mm
- Small size in popular 'R-Shape'
- Versions with synchronisation input
- Measurement independent of material, surface, colour and size of target
- Works under dust, dirt, fog, light
- Detect transparent and bright objects
- Water tight, IP 67, ATEX 22, oil resistant, robust
- Customized versions available
- Swiss made



download data sheet on your smart phone with a QR-Code scanner app.



New!
oil resistant thanks to Viton®
ATEX 22

Technical specifications

		UPX 150	UPX 500
Detection range	mm	0...150	0...500
Adjustment range of binary output (with potentiometer)	mm	60...150	120...500
Hysteresis of binary output, axial	%	~10...40	~10
		adjustable with potentiometer	
Reproducibility	%FS		<1
Operating frequency	kHz	~350	~175
Status indicator	-	LED red	
Binary output, short circuit proof, max. 0.1A	-	by choice PNP, NPN, NO, NC	
Switching frequency	Hz	~15	~2
t _{on} binary output	ms	<5	<10
t _{off} binary output	ms	<40	~400...8000
		adjustable with potentiometer	
Power supply voltage (reversal polarity protection)	VDC		12...28
Ripple of supply voltage	%		<10
Mean consumption, switched without load	mA	~45	~55
Peak current, switched without load	mA	100/0.05ms	250/0.1ms
Temperature coefficient of sensor	%/°K		typ. -0.1
Temperature coefficient of air path	%/°K		-0.17
Ambient temperature during operation	°C		0...+50
Sensor temperature during operation	°C		0...+70
Pressure range	mbar _{abs}		~900...1100
Mass without cable	g		~50
Protection class	-		IP67
ATEX zone 22 for category 3D (non conductive dust)	-		EEx II 3D T80°C
Housing material	-		Polyamide and stainless steel
Electrical connection	-		M8 connector or integrated cable

www.sntag.ch

This Information corresponds to the current state of knowledge. SNT reserves the right to make technical changes. Do not use these products in any application where failure of the product could result in personal injury. Liability for consequential damage resulting from the use of SNT products is excluded.

SNT Sensortechnik AG, Hammerstrasse 6, CH-8180 Bülach, Switzerland, Phone +41 44 817 29 22, Fax +41 44 817 10 83, info@sntag.ch

Model selection

Thanks to the new transducer sealing made of Viton® the UPX sensors are very robust against many environmental influences. In particular, they are oil resistant, unlike many other ultrasonic sensors.

The main difference between the two UPX models is their different detection range (reach and shape). Also switching speed is different.

UPX 150 ...

Very narrow detection zone. Useful for looking into small orifices. Fast reaction time t_{on} . For fast counting/detecting up to 150mm distance and for level control as well. Binary output only. Axial hysteresis can be adjusted with potentiometer from approx. 5...50mm, depending on switching distance. This enables e.g. also a min./max. level control.

UPX 500 ...

General purpose proximity switch with fast reaction time t_{on} and slower t_{off} delay. The delay can be adjusted with potentiometer between 0.4...8s. Detection zone with \varnothing ~90mm. Binary output only.

Blind range

The lower detection range is called blind range. It is typical for ultrasonic sensors. In the blind range no distance measurement is possible. However the pure function as proximity switch (binary output), as used on the UPX series, is possible in the blind range with certain restrictions (only bigger objects).

Binary output

The binary output becomes active, i.e. it switches on or off, when a scanned object falls below the set distance or if it exceeds it. Each switch point has a hysteresis (see technical specifications). This is the difference between switch on and switch off point during approach or departure. Hysteresis is necessary for an appropriate switching behavior.

The switching distance is set with the potentiometer. An object with reasonable size and perpendicularly to the sensor axis is placed at the desired distance from the sensor. The potentiometer is now turned from left slowly clockwise until the LED illuminates (NO) or expires (NC). Thus the switching distance for the binary output is set.

Synchronisation input (Y versions)

The ultrasonic signals can disturb each other when several sensors are focused on the same target or when sensors are mounted close together. This can be avoided by synchronizing the sending pulses. The synchronisation leads of all sensors are connected to each other by shielded cables

as short as possible. Since all sensors send then simultaneously, the current consumption increases heavily. Not used synchronisation leads shall be isolated.

Inclination angle of object

Smooth surfaces can be detected up to an inclination angle of 7° (UPX 150) and 10° (UPX 500). However rough and structured (granular) surfaces can be detected up to much higher angles.

Mounting

Ultrasonic sensors should be mounted softly in order to keep external acoustic noise away from the sensor. The UPX sensors can be mounted in two ways, with two M4 screws through the two holes in the housing or on the M18 thread of the transducer as well. A rubber gasket should be used between the sensor and the mounting spot. Included with the sensor are an M18 nut, a washer and a rubber sleeve for mounting on the M18 transducer. The rubber sleeve is sized for a mounting hole of $\varnothing 21\text{mm}$.

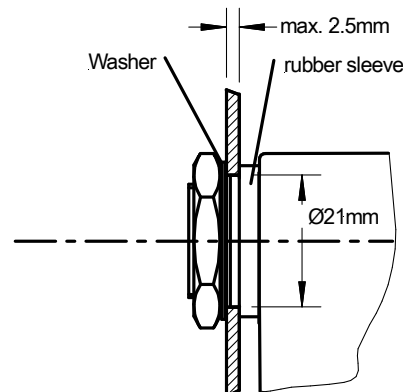

Cable

The sensors have a 3- or 4-pin M8 connector for screw or snap-on connection or an integrated cable. The cable should be kept as short as possible. Maximum cable length is approx. 100m, if cross section area is appropriate (peak current of 100 or 250mA, use 470 μF /35V backup capacitor close to sensor). The cable should not be mounted parallel or close to high current cables.

Cables for connection to the M8 connector have to be ordered separately.

Power supply

Ideally a power supply is used exclusively for the sensor. The power supply must be able to supply the short peak current of approx. 100mA (UPX 150) or 250mA (UPX 500). In order to avoid disturbances the part where the sensor is mounted must be correctly earthed.

Detection beam

The detection beam of an ultrasonic sensor has the shape of a cone. The size depends on the target and its sound reflecting characteristics. Small and more badly reflecting objects result in a smaller cone (narrower and shorter). Bigger objects and those with surfaces which are not perpendicular to the central axis can expand the cone. The exact cone shape and size can be determined only at the object itself. No disturbing objects must be between the sensor and the target within the cone. Otherwise the sensor would detect the disturbing object instead of the desired target. On the right the typical cone shapes for the UPX sensors are shown. The difference between bold and dotted line represents the variation due to different targets. Furthermore the size of the detection beam is influenced by air temperature and humidity. The colder and dryer the air, the larger is the beam.

No other ultrasonic sensor working at the same frequency shall be within the cone or close to it or opposite to it. This is only allowed when using the synchronisation option (Y-version).

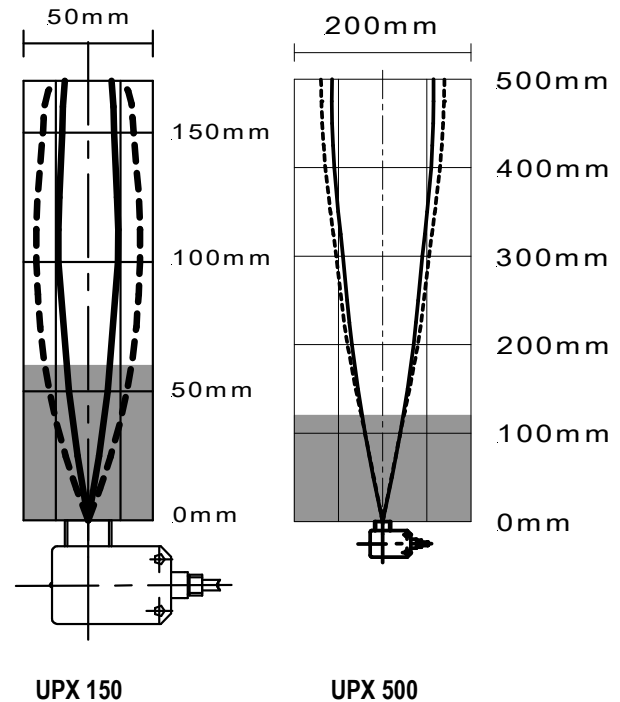
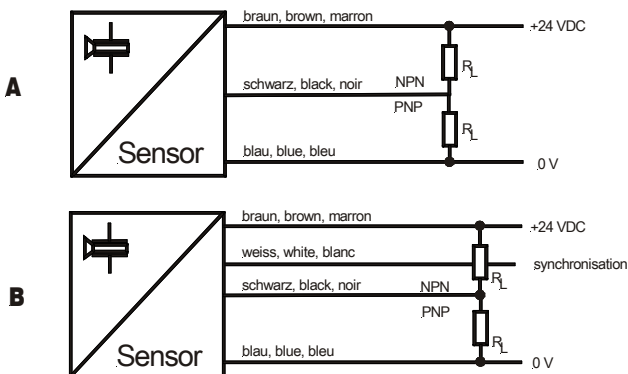

Diagram of connections



Parts included

- Sensor
- M18 nut, washer and rubber sleeve for mounting
- Miniature screw driver for potentiometer

Dimensions

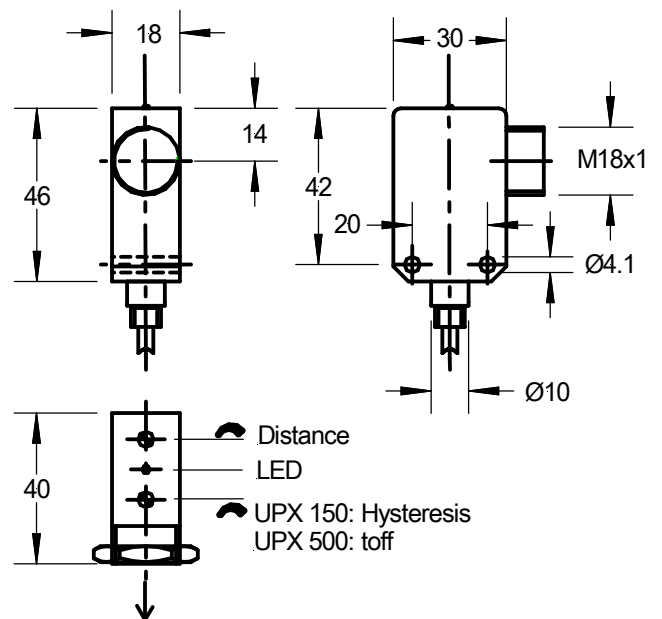

Use the miniature screw driver which is included for adjustment of the two potentiometers.

Standard versions

Type	Detection range	Description	Scheme
UPX 150 PVPS 24	150mm	PNP NO, 2m integrated cable	A
UPX 150 PVPS 24 C	150mm	PNP NO, 3-Pin connector	A
UPX 500 PVPS 24	500mm	PNP NO, 2m integrated cable	A
UPX 500 PVPS 24 Y	500mm	PNP NO, synchronisation input, 4-Pin connector	B
UPX 500 PVPS 24 C	500mm	PNP NO, 3-Pin connector	A
Option		NPN instead of PNP	
Option		NC instead of NO	

Basically all possible versions are available according to the following key:
 Detection range: XXX: 150 = 170mm, XXX: 500 = 500mm

Product key

UPX XXX PV □ □ 24 □ □

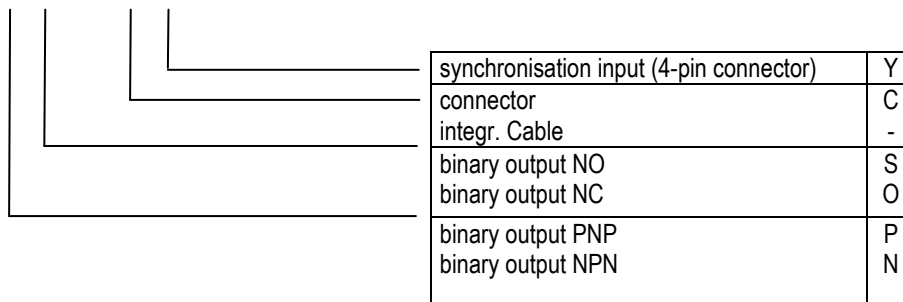

Accessories (see also data sheet ,ACC')

Cables 4-pin with M8 screw connector, PUR:

with straight connector: l=2m Type KAB 2K4VGPUR
 l=5m Type KAB 5K4VGPUR
 with 90° connector: l=2m Type KAB 2K4VWPUR
 l=5m Type KAB 5K4VWPUR

Cables 3-pin with M8 screw connector, PUR:

with straight connector: l=2m Type KAB 2K3VGPUR
 l=5m Type KAB 5K3VGPUR
 with 90° connector: l=2m Type KAB 2K3VWPUR
 l=5m Type KAB 5K3VWPUR

Some typical ultrasound applications

Level measurement

- Measuring level in small containers
- Water gauge measurement
- Monitoring liquid levels in bottling plants
- Checking for tailbacks on conveyor belts
- Monitoring contents of granulate hoppers

Process control

- Controlling belt tension or sag
- Sensing and signaling valve positions
- Measuring roll diameter on reeling machines
- Monitoring the height of stacks (charges, storehouse)
- Detecting material feed
- Detecting the feed of strip stock to blanking machines

Counting / Detection

- Counting onlookers at freestanding sales displays
- Access supervision at rotating doors, counters etc.
- Door automation
- Detecting transparent objects, foils, flat glass, bottles etc.
- Sensing objects in robot grippers
- Recognizing full or empty pallets
- Count and detect objects with 'difficult' surface
- Detect wrong parts on conveyors
- Collision protection on vehicles

Scanning of dimensions

- Determining the dimensions of packages
- Sensing the height of plants in automated green houses

www.sntag.ch