



## K30

Din rail mounting controller  
with mini-programmer, wattmeter  
and independent timer functions

### APPLICATION SECTORS

- Shoemaking Machineries
- Glueing and binding machines (hot glue)
- Packaging and blister packing machines
- Paint booths
- T-shirt printing
- Climatic chambers
- Hot runner
- Glass bending ovens
- Extruders
- Industrial baking or large kitchens
- Continuous multi-zone ovens (for PCB, for leather goods, etc.)
- Ceramics ovens
- Heat-treatment ovens
- Ovens for goldsmiths and dentists
- Simple cascade controls

- Input for TC, RTD, PTC, NTC, mA or V
- **2 independent serial interfaces** to contemporarily dialog with a supervisor and a remote panel
- **Up to 5 digital outputs** : one SSR output (standard) and up to 4 relay or SSR outputs
- **User Calibration**
- H/C PID Control with overshoot control, self-tune and **2 Autotuning algorithms**
- **8 segment programmer function** with events recovery, **2 events** and guaranteed soak
- **Independent timer** with 4 functioning modes
- **Wattmeter** for calculating the instantaneous power and energy used
- **Counter** for days and hours worked with programmable threshold for **programmed maintenance**
- Parameter sequence freely programmable
- Delay at the start up function
- Ramp to set point change
- Soft start

**DOUBLE SERIAL INTERFACE**

**MAIN OBJECTIVES**

- simplify the assembling and maintenance of medium-sized machines (such as medium-sized incubators, climatic chambers, bread/pizza ovens as well as fridges, machines for the shoe-making industry, etc) separating the output part (to which all the signals are also connected) from the human-machine interface (that is connected to the power unit by a simple 5 pole cable)
  - allow the front to be positioned in a user-friendly and attractive way without having to compromise on "isolation distance", "board depth" or any other chosen limit.
  - make it possible to personalize the machine front in an easy and cheap way while using a "serial" instrument.
- All of this still allows these instruments to dialogue with external units such as supervisors, data loggers, PLCs, etc without this interfering with the normal running of the machine.

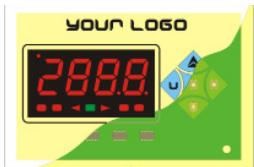

Personalized solution

In other words:

- 1) Reduction and simplification of the cabling
- 2) Improved access to the parts during production as well as during maintenance
- 3) Easily personalized front-end of machine
- 4) Positioning without "compromises" or limits



Standard solution

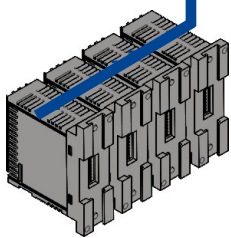
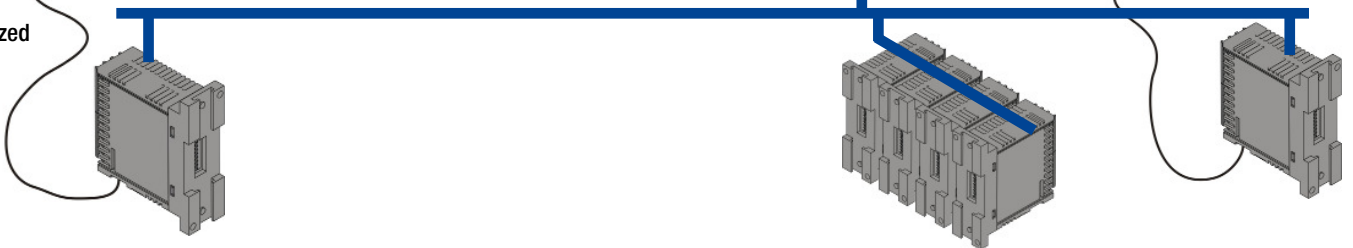

**WHY NO DISPLAY ?**

Whenever a sophisticated HMI is needed or is already present for other reasons, it is possible to use this resource for instrumentation too. There are several advantages: more simple cabling can be used, holes in the panels can be avoided, it is possible to connect the instrument where there is available space or near to the point where they are of use and, in many cases, control panel size can also be reduced.

**Example:** continuous 10 zone oven of a total length of 30 meters.

**Solution 1:** 10 panel instruments grouped together in a single board.

The board must be able to receive the 10 instruments (and therefore have 10 holes), in a position that is convenient for the user. The human-machine interface is that of the instrument and cannot be personalized.

At least the following must be connected to each instrument: a probe (calculating one zone every 3 meters, no less than 250 meters of compensated cable is needed) and the power supply (a further 250 meters of electric cable of suitable section).

**Solution 2:** back-of-board instruments connected close to the corresponding actuator.

If the instruments are positioned near to the zone that they regulate and all are connected by a serial line to an operator panel, the board only needs to be able to receive the operator panel (just one hole) at the front, a compensated cable is not required and a single power line is sufficient (30 meters). Finally, with only 30 meters of triple cable for signals, it is possible to gather all information necessary in real-time.

**TWO AUTOTUNING ALGORITHMS**

In order to meet the clients' needs and those of their production processes, TECNOLOGIC have developed two autotuning algorithms (as well as adaptive self-tuning): Oscillatory autotuning and the "fast" type.

- **Oscillatory autotuning** is the classic type that requires 3 oscillations to be made around a set point. This type of tuning is particularly accurate and can be set up at any moment. However, it takes a long time and generates an overshoot that, although not exaggerated, may not be appreciated.
- **Fast autotuning** on the other hand is much faster and therefore particularly suitable for very slow processes. Another of its characteristics is that it does not generate overshoot (the algorithm aims at keeping the PV under the set point). Finally fast autotuning, applied in multi-loop systems, feels the "dragging" effects produced by neighbouring loops much less and is therefore particularly suitable for machines such as extruders, hot-runners, continuous ovens, etc.

# Din rail mounting controller

## TECHNICAL FEATURES

### ELECTRICAL DATA

#### Power supply:

- 100-240 V AC ( $\pm 10\%$ ) 50/60 Hz
- 24 V AC/DC ( $\pm 10\%$ ) 50/60 Hz (available soon)

#### Power consumption: max 6 VA

#### Device Class: Class II

#### Nominal pulse voltage: 2,5 KV

#### Category of overvoltage: II

**Isolation:** reinforced between low voltage (supply and output relay) and frontal parts. Reinforced between low voltage and very low voltage parts (input, static outputs). No isolation between input and static outputs. 50V isolation between RS485 and very low voltage parts.

### THERMOCOUPLE INPUT

#### Type: J,K,S,R,T programmable

**Line resistance:** 100  $\Omega$  max with error  $<\pm 0.1\%$  of the input range width

**Unit of measurement:**  $^{\circ}\text{C}$  or  $^{\circ}\text{F}$  programmable

**Cold junction:** automatic compensation from 0 to  $+50^{\circ}\text{C}$

**Cold junction accuracy:** 0,1  $^{\circ}\text{C}/^{\circ}\text{C}$  @  $25^{\circ}\text{C}$  after a warm-up (instrument switch-on) of 20 min

**Calibration:** according to EN 60584-1

**Burn-out:** at the end of scale

TC Type	Range	
J	From 0 to 1000 $^{\circ}\text{C}$	From 32 to 1832 $^{\circ}\text{F}$
	From 0.0 to 999.9 $^{\circ}\text{C}$	From 32.0 to 999.0 $^{\circ}\text{F}$
K	From 0 to 1370 $^{\circ}\text{C}$	From 32 to 2498 $^{\circ}\text{F}$
	From 0.0 to 999.9 $^{\circ}\text{C}$	From 32.0 to 999.0 $^{\circ}\text{F}$
S	From 0 to 1760 $^{\circ}\text{C}$	From 32 to 3200 $^{\circ}\text{F}$
	From 0.0 to 999.9 $^{\circ}\text{C}$	From 32.0 to 999.0 $^{\circ}\text{F}$
R	From 0 to 1760 $^{\circ}\text{C}$	From 32 to 3200 $^{\circ}\text{F}$
	From 0.0 to 999.9 $^{\circ}\text{C}$	From 32.0 to 999.0 $^{\circ}\text{F}$
T	From 0 to 400 $^{\circ}\text{C}$	From 32 to 752 $^{\circ}\text{F}$
	From 0.0 to 400.0 $^{\circ}\text{C}$	From 32.0 to 752.0 $^{\circ}\text{F}$

### THERMORESISTANCE INPUT (RTD)

#### Type: Pt 100 3 wires

#### Current: 135 $\mu\text{A}$

**Line resistance:** automatic compensation up to 20  $\Omega$ /wire with maximum error  $<\pm 0.1\%$  of the input span

**Unit of measurement:**  $^{\circ}\text{C}$  or  $^{\circ}\text{F}$  programmable

**Burn-out:** at the end of scale

**Calibration:** according to EN 60751/A2

RTD Type	Range	
Pt 100	From -200 to 850 $^{\circ}\text{C}$	From -328 to 1562 $^{\circ}\text{F}$
	From -200.0 to 850.0 $^{\circ}\text{C}$	From -328.0 to 999.9 $^{\circ}\text{F}$

### THERMISTOR INPUT

**Type:** KTY 81-121 (990  $\Omega$  @  $25^{\circ}\text{C}$ ) and NTC 103AT-2 (10 K $\Omega$  @  $25^{\circ}\text{C}$ )

**Unit of measurement:**  $^{\circ}\text{C}$  or  $^{\circ}\text{F}$ , programmable

Type	Range	
KTY 81-121	From -55 to 150 $^{\circ}\text{C}$	From -67 to 302 $^{\circ}\text{F}$
	From -55.0 to 150.0 $^{\circ}\text{C}$	From -67.0 to 302.0 $^{\circ}\text{F}$
NTC103 AT-2	From -50 to 110 $^{\circ}\text{C}$	From -58 to 230 $^{\circ}\text{F}$
	From -50.0 to 110.0 $^{\circ}\text{C}$	From -58.0 to 230.0 $^{\circ}\text{F}$

### LINEAR SIGNALS INPUT

**Type:** 0/10-50 mV, 0/12-60 mV, 0/4-20 mA, 0/1-5 V, 0/2-10 V

**Visualization:** programmable from -1999 to 9999

**Decimal point:** programmable

**Burn-out:** (only for zero suppression signals) Burn-out signaling when the input signal is less than 5% of the input field

#### Auxiliary supply for 0/4 - 20 mA transmitters:

- **Type:** not isolated and not protected against short-circuit
- **Load:** 10 V @ 20 mA.

#### Input impedance:

- 51  $\Omega$  for mA input
- $>1\text{ M}\Omega$  for mV and V input

### DIGITAL INPUTS

**Type:** for free-voltage contacts

**Max contact resistance:** 10  $\Omega$

**Contact load:** 10 V, 6 mA

### OUTPUTS

**Function:** programmable

**Output action:** direct/reverse, programmable

**Type:**

#### a) Relay outputs

**Contact:** - SPDT or SPST-NO

**Contact Load:** see the "How to order"

**Relay electric life:** 100000 operations

#### b) Logic tension to drive a solid state relay

**Isolation:** Output **NOT** isolated as regards the very low voltage parts

**Logic state 1:** 12 V  $\pm 20\%$  @ 1 mA  
10 V  $\pm 20\%$  @ 20 mA

**Logic state 0:**  $<0.5\text{ V}$

**Note:** the selection "output 5" or "supply for transmitter" is programmable.

### POWER OUTPUT SENSOR

**Isolation:** Output not isolated and not protected by the short circuit

**Tension:** 12 VDC

**Current:** 20 mA Max

### SERIAL INTERFACES (independent)

#### Serial 1 (standard)

**Type:** proprietary

**Isolation:** not isolated in respect to very low voltages parts

**Protocol:** proprietary

**Electrical levels:** TTL

#### Serial 2 (optional)

**Type:** RS485

**Isolation:** functional (50 V) in respect to very low voltages parts

**Protocol:** Modbus RTU

**Electrical levels:** according to EIA standards

**Baud rate:** from 1200 to 38000 baud

**Parity:** none

**Data formed:** 8 bit + 1 start bit + 1 stop bit

### ENVIRONMENTAL DATA

**Pollution category:** 2

**Installation category:** II

**Operating temperature:** from 0 to  $50^{\circ}\text{C}$

**Operating humidity:**  $< 95\text{ RH}\%$  without condensation

**Storage temperature:**  $-25^{\circ}\text{C}$  to  $60^{\circ}\text{C}$

### FUNCTIONAL DATA

**Control:** - single action PID, double action PID

- ON/OFF, Neutral Zone ON/OFF

**Overall accuracy:**  $\pm (0,5\% \text{ span} \pm 1 \text{ digit} @ 25^{\circ}\text{C})$ ;

Tc S:  $\pm (1\% \text{ span} \pm 1 \text{ digit} @ 25^{\circ}\text{C})$

**Sampling rate:** 130 ms

**Display updating time:** 500 ms

**Common-mode rejection:** 120 dB to 50/60 Hz

**Normal-mode rejection:** 60 dB to 50/60 Hz

**Conformity:** EMC 2004/108/CE (EN 61326) Directive, LV 2006/95/CE (EN 61010-1) Directive.



# K 30

## MECHANICAL DATA

- Housing:** UL 94 V0 self-extinguishing plastic  
**Mounting:** on Omega DIN rail or on wall  
**Dimensions:** 35 x 88 mm, height 88 mm  
**Weight:** 180 g approx.  
**Terminal block:** extractable, 24 screw terminals (screw M3 for cables from 0.25 to 2.5 mm<sup>2</sup> or from AWG 22 to AWG 14 )  
**Protection degree:**  
 - IP40 according to EN 60070-1 for indoor use  
 - Screw terminal: IP20



## ACCESSORIES

### P30, P32 - Remote panels

- Makes it possible to:
- Visualize and manage parameters up to 1,5 m from the main unit
  - it is supplied by the main unit and therefore its cables have very low voltage tension



### A01 - Programming key

- Makes it possible to:
- Memorize the configuration of an instrument to transfer it to other instruments
  - Transfer a configuration to a PC
  - Memorize a configuration recorded in a PC
  - Let the instrument "converse" directly with a PC.



### WinTec - Supervisor

- Data Acquisition
- Supervision
- Alarm management
- Recipe management
- Trend
- Reports.

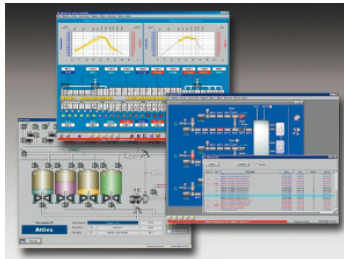

## DIMENSIONS (mm)

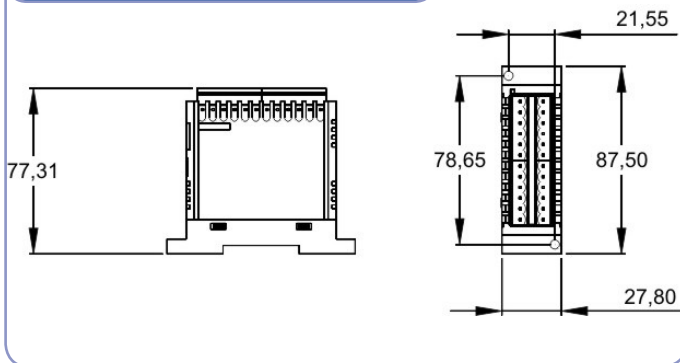

### Notes :

- In the above drawing the mechanical dimensions of the terminal block are not reported because they depends and may change from one model to another.
- Please consider a distance of approx. 2 cm between one regulator to another, whenever more instruments are mounted on the same DIN rail.

# DIN rail mounting controller

## HOW TO ORDER

- K30** - Controller  
**K30T** = Controller + timer  
**K30P** = Controller + timer + programmer

### Power supply

- L** = 24 V AC/DC  
**H** = 100 - 240 V AC

### Inputs (2 digitals inputs are standard)

- C** = J, K, R, S, T, PT100, 0/12...60 mV  
**E** = J, K, R, S, T, PTC, NTC, 0/12...60mV  
**I** = 0/4...20 mA  
**V** = 0...1V, 0/1...5V, 0/2...10V

### Out 1

- R** = SPDT 8 A Relay (resistive)  
**O** = VDC for SSR

### Out 2

- = Not available  
**R** = SPDT 8 A Relay (resistive)  
**O** = VDC for SSR

### Out 3

- = Not available  
**R** = SPST-NO 5 A Relay (resistive)  
**O** = VDC for SSR

### Out 4

- = Not available  
**R** = SPST-NO 5 A Relay (resistive)  
**O** = VDC for SSR

### Communication

- = TTL ModBus  
**S** = RS 485 ModBus

**Note :** it is always available also an additional Out 5 for SSR driving.

## CONNECTIONS

